

VARIO Ped 1-70 Pedestal

VARIO PED 1-70 Pedestal



Part No. S2302-0001

Copyright © 2022
All rights reserved.

Original Instructions: English

All rights reserved throughout the world. No part of this publication may be stored in a retrieval system, transmitted, copied or reproduced in any way, including, but not limited to, photocopy, photograph, magnetic or other record without the prior agreement and permission in writing of Videndum Plc.

Disclaimer

The information contained in this publication is believed to be correct at the time of printing. Videndum Ltd reserves the right to make changes to the information or specifications without obligation to notify any person of such revision or changes. Changes will be incorporated in new versions of the publication.

We are making every effort to ensure that our publications are updated on a regular basis to reflect changes to product specifications and features. Should this publication not contain information on the core functionality of your product, please let us know. You may be able to access the latest revision of this publication from our website.

Videndum Production Solutions Ltd reserves the right to make changes to product design and functionality without notification.

Trademarks

All product trademarks and registered trademarks are the property of Videndum Plc.

All other trademarks and registered trademarks are the property of their respective companies.

Published by:

Videndum Production Solutions Ltd

Email: publications@videndum.com

Safety	2	Operation	20
Warning Symbols Used in these Instructions	2	Height adjustment	20
Intended Use	2	Lower stage	20
Health and Safety	2	Top stage	21
Mounting and Installation	2	Brakes	21
Water, Moisture and Dust	3	Cable guards	21
Operating Environment	3	Pedestal movement	22
Cleaning	3	Changing the skid tracking width	24
Maintenance	3	Optional wheels	25
Critical Data	3	Transportation and storage	26
Usage	4	Maintenance	28
About this Guide	4	Servicing	28
Introduction and Description	4	General	28
Components and Connections	5	Cleaning	28
Box Contents	5	Routine Maintenance	28
Optional Accessories	8	Adjustments	28
Assembling the Pedestal	9	Bottom clamp adjustment	29
Installation	9	Skid clamp adjustment	30
Column	10	Replacing gas struts	30
Pressurizing the pedestal	11	Technical Specification	32
Pressurizing using the portable pump	14	Physical Data (Vario Ped 1-70 S2302-0001)	32
Pressurizing from an external pressure source	15	Environmental Data	33
Fitting and balancing the load	18		
Heavy Duty Quickfix Adaptor (optional)	18		

Safety

Important information on the safe installation and operation of this product. Read this information before operating the product. For your personal safety, read these instructions. Do not operate the product if you do not understand how to use it safely. Save these instructions for future reference.

Warning Symbols Used in these Instructions

Safety cautions are included in these instructions. These safety instructions must be followed to avoid possible personal injury and avoid possible damage to the product.



WARNING!

Where there is a risk of personal injury or injury to others, comments appear supported by the warning triangle symbol.

Where there is a risk of damage to the product, associated equipment, process or surroundings, comments appear supported by the word '**CAUTION**'.



WARNING symbols on the pedestal

On encountering the warning triangle and open book symbols it is imperative that you consult this operators guide before using this pedestal or attempting any adjustment or repair.



Intended Use

The VARIO 1-70 pedestal is designed for use in television studios or OB applications to support and balance a fluid head, camera and ancillary equipment weighing up to 70 kg (154 lb).

This product is intended for use on an unobstructed and reasonably level surface by television camera operators.

Health and Safety



WARNING! Risk of personal injury or injury to others. All personnel must be fully trained and adhere to correct manual handling techniques and Health & Safety regulations. It is the responsibility of the local organisation to enforce safe working practices at all times..



WARNING! 39.5 kg / 87.1 lb LIFTING ASSISTANCE REQUIRED. Do not lift this product without the assistance of another person or a lifting hoist capable of safely lifting the product.

Mounting and Installation



WARNING! Before fitting, adjusting, or removing the payload, the elevation column must be lowered to a safe working height and wheel brakes must be applied



WARNING! An abnormal or unbalanced payload can cause the product to become unstable. Strictly adhere to the payload guidelines and mounting instructions presented in this user guide



WARNING! When mounting the payload, sufficient clearance must be provided below the mounting platform to prevent the risk of collisions or trapping injuries when the column is lowered.



WARNING! The product has been designed for mounting a payload consisting of camera support equipment only. Under no circumstances should the product be used for the transportation or support of personnel.



WARNING! Risk of product instability when moving the product with the elevation column fully extended. Reduce the height of the elevation column to a safe lower level before attempting to move the product.



WARNING! The product must only be operated on a smooth and level surface.



WARNING! The product must always be secured (all three wheel brakes applied) when left unattended. Do not leave the product unattended on a sloping surface.



CAUTION! Do not exceed the payload limit for the product of 70 kg (154 lb).



CAUTION! The product must only be operated with a minimum payload of 10 kg (22 lb) to pre-load the column correctly.

Water, Moisture and Dust



WARNING! Protect the product from water, moisture and dust.

Operating Environment



WARNING! The product should not be used outside the operating temperature limits. Refer to the product technical specifications for the operating limits for the product.

Cleaning



CAUTION! Do not use solvent or oil-based cleaners, abrasives or wire brushes. Clean with a dry lint free cloth.

Maintenance



WARNING! The fitting of non-approved parts or accessories, or the carrying out of non-approved alterations or servicing can be dangerous and could affect the safety of the product. It may also invalidate the terms and conditions of the product warranty.

Critical Data

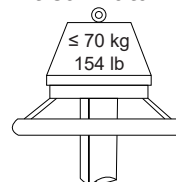

Load

Maximum load: 70 kg / 154 lb

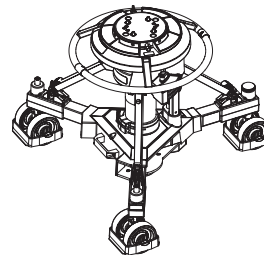

Mass

Pedestal unladen:
Studio Weight: 39.5 kg / 87.1 lb



Pressure

Maximum pressure: . . . 11.7 bar (170 psi)

≤ 11.7 bar (170 psi)

Usage

The Vario Ped 1-70 pedestal is designed for use in television studios and on location to support and balance a fluid head, camera and ancillary equipment weighing up to 70 kg / 154 lb.

This product is intended for use on an unobstructed and reasonably level surface by television camera operators.



WARNING!

Do NOT attempt to use this product if you do not understand how to operate it.

Do NOT use this product for any other purpose than that specified in the Usage statement above.

Maintenance beyond that detailed in this Operators Guide must be performed only by competent personnel in accordance with the procedures.

About this Guide

The operators guide is issued for the Vario Ped 1-70, part no S2302-0001. The guide provides instructions for operation and routine maintenance.

Introduction and Description

The Vario Ped 1-70 is fully steerable and is capable of handling payloads up to 70 kg / 154 lb. It has 2 stages for achieving very high and low shots, and the upper stage is perfectly balanced for on shot tracking of talent.

It has an integral manual pump and an inlet valve for use with an external supply, making Perfect Balance easy to achieve. There is an optional storage area for the camera operator. In addition, the pedestal includes a pressure gauge for clear and reliable set-up and the detachable skid allows the pedestal to be simply broken down into two sections for easy storage and transportation.

It has a selector for both single wheel and all wheel crab steering for working in tight spaces and on shot direction changes. It comes with 12.5cm / 5 inch wheels with adjustable cable guards.

Key features:

Upper stage perfect balance for on-shot performance.

Balance assisted second stage for easy elevation and extended height range.

Full crab and steer facilities controlled from a central steering ring for enhanced manoeuvrability and on-shot steering.

Built in pressure gauge and manual pump for easy counterbalance set-up.

Detachable skid for easy transport and storage.

Wheel rim braking mechanism eliminates tyre flat spots for smooth rolling shots

Column can be adapted to work on dolly track



Scan this QR code to access a dedicated page containing important information:

- Safety / educational videos
- Exploded diagrams leading to the Parts Store
- Recycling information and life cycle upgrades
- Warranty information & links to registration / submit case to service team/case management
- User manuals
- Easy access to service centre
- This QR code is also on the Pedestal for easy reference.

Box Contents

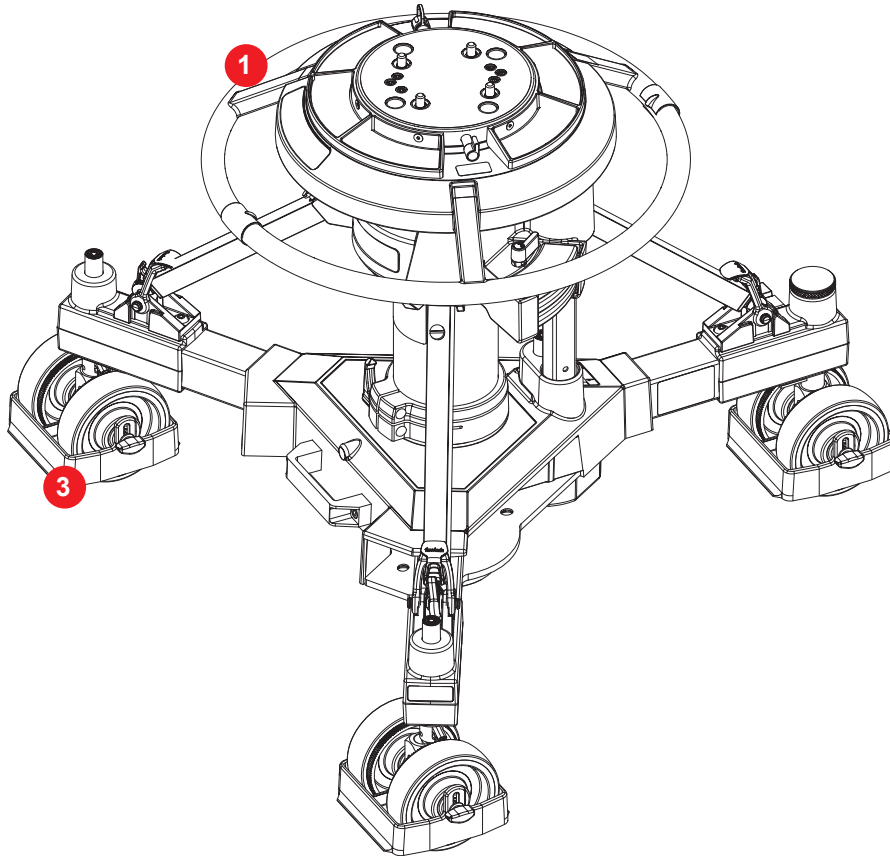

Item	Description
1	Vario Ped 1-70 S2302-0001
2	Trim weights x 6
3	Skid + Studio wheels
4	Manual Pump

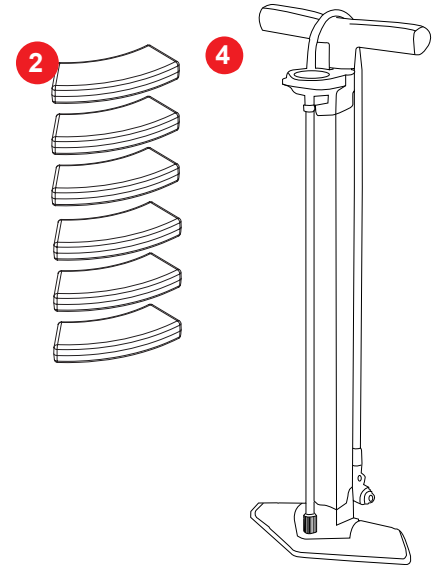

Components and Connections

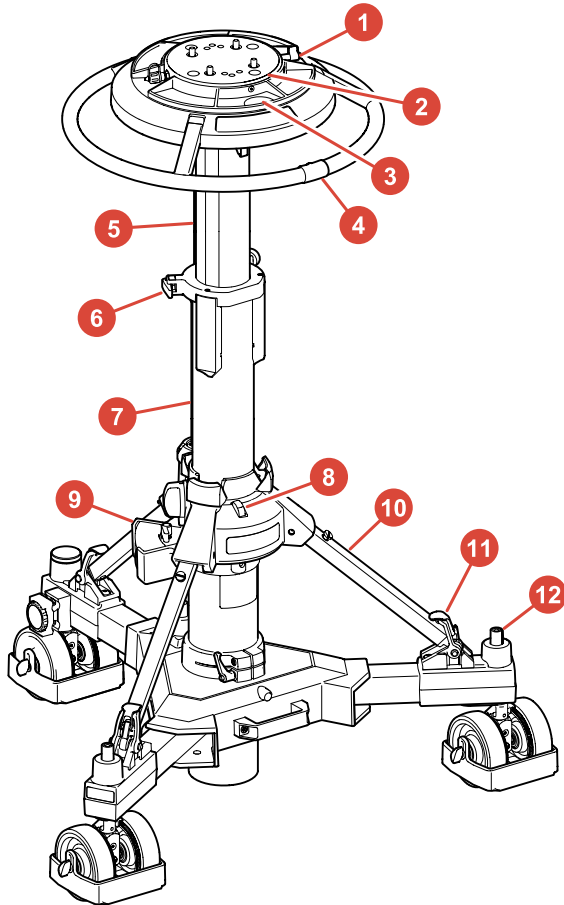

Item	Description
1	Control valve
2	Four-bolt mounting plate
3	Pressure gauge
4	Steering indicator
5	Top stage
6	Top clamp
7	Bottom stage
8	Safety catch
9	Trim weight stowage
10	Short strut
11	Foot support and strap
12	Wheel brake foot-button

Components and Connections

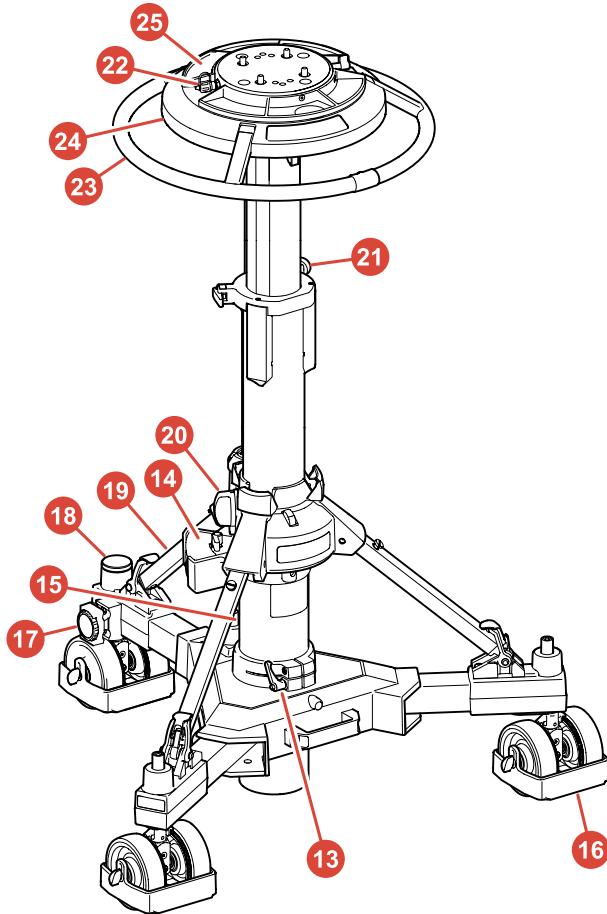

Item	Description
13	Skid clamp
14	Trim weight
15	Crab/Steer changeover foot-button
16	Cable guard
17	Cable clamp
18	Tiller socket
19	Fixed strut
20	Bottom clamp
21	Drag control
22	Schrader valve and cap
23	Removable steering ring
24	Steering ring mounting plate
25	Weight tray

Components and Connections

Optional Accessories

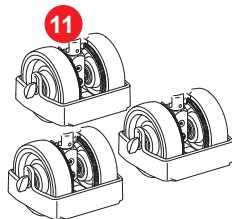
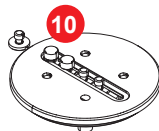
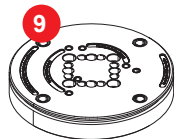
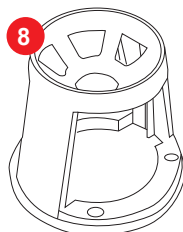
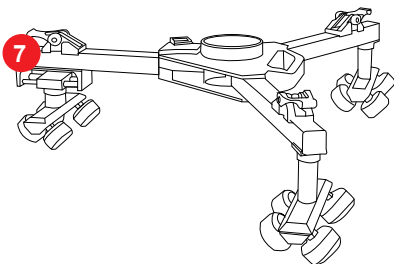
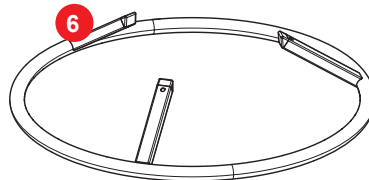
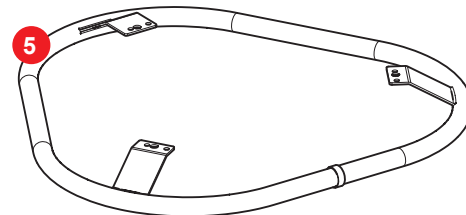
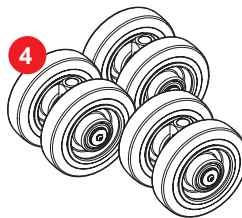
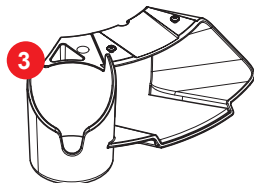
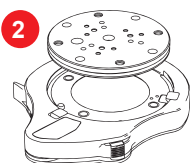
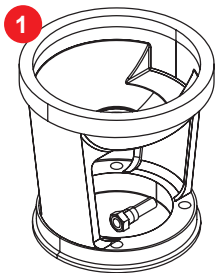

Item	Description	Part No.
1	150mm Bowl Adaptor	3330-17
2	Quickfix kit	3912
3	Pedestal Accessory Holder	V4172-1003
4	OB Wheels	3329-30
5	Kick ring	3329-32
6	Steering Ring Large	3429-21
7	Tracking Dolly / Skid	3369-57
8	100mm Bowl Adaptor	3330-16
9	Base Adaptor	08348
10	PTZ and Prompter plate	V4166-1002
11	Studio Wheels	3329-43

Assembling the Pedestal

1. Turn the skid upside-down, depress the leg locking plungers and swing each folding leg out until the plungers lock the legs in the fully open position.
2. Set the skid on the ground on its wheels and apply the brakes (3).
3. Ensure that the rubber straps on each foot support (2) are to the outside of the ball joint.

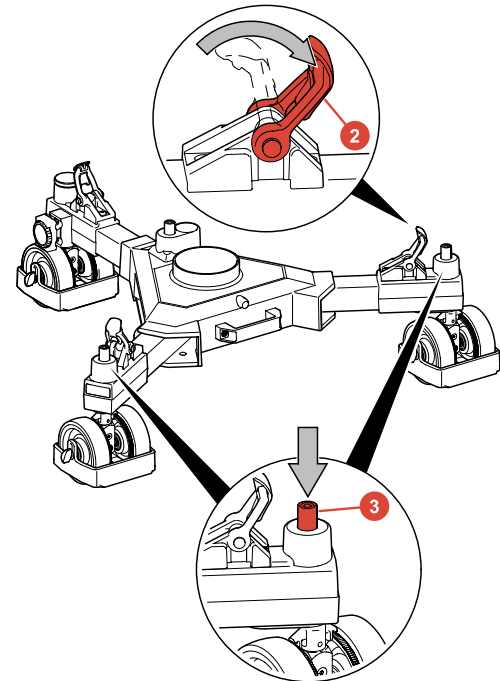
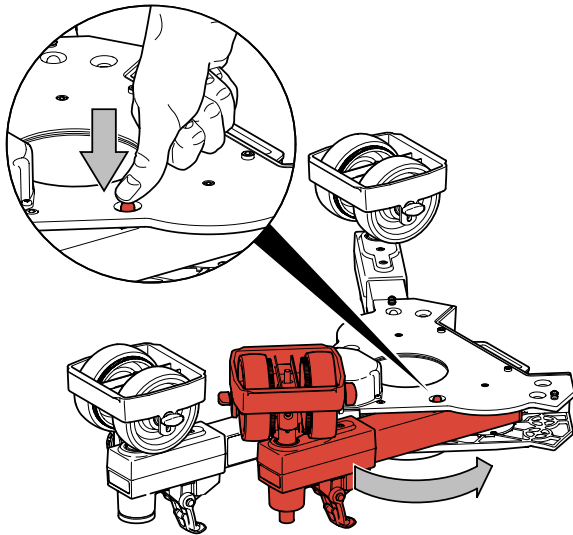

Installation

Column

Install the column on the skid as follows:

1. Ensure that the rubber straps on each foot support (11) are to the outside of the ball joint.
2. Hold the column upright. Raise the struts (20) to about 30° from horizontal. The strut joints are adjusted to retain the strut in this position.
3. Lift the column, align the fixed strut with the fixed leg of the skid (there is also an engraving on the skid to assist aligning the column) and carefully lower the column into the skid centre. Ensure that the struts engage with the ball joints on each foot support and the steering tube locates in its socket.
4. Secure the struts to the supports with the rubber straps (11).
5. Tighten the skid clamp (14), using moderate hand pressure only. The clamp lever has a spring-loaded ratchet-type action and is operated as follows:
 6. Turn the clamp lever clock-wise as far as possible.
 7. Pull the lever outward against the spring pressure, return it to vertical and release.
 8. Turn lever clockwise again.
 9. Repeat until the skid clamp is sufficiently tightened.
10. Slide the steering indicator(s) (4) to the desired position (See **Pedestal movement** on page 22)

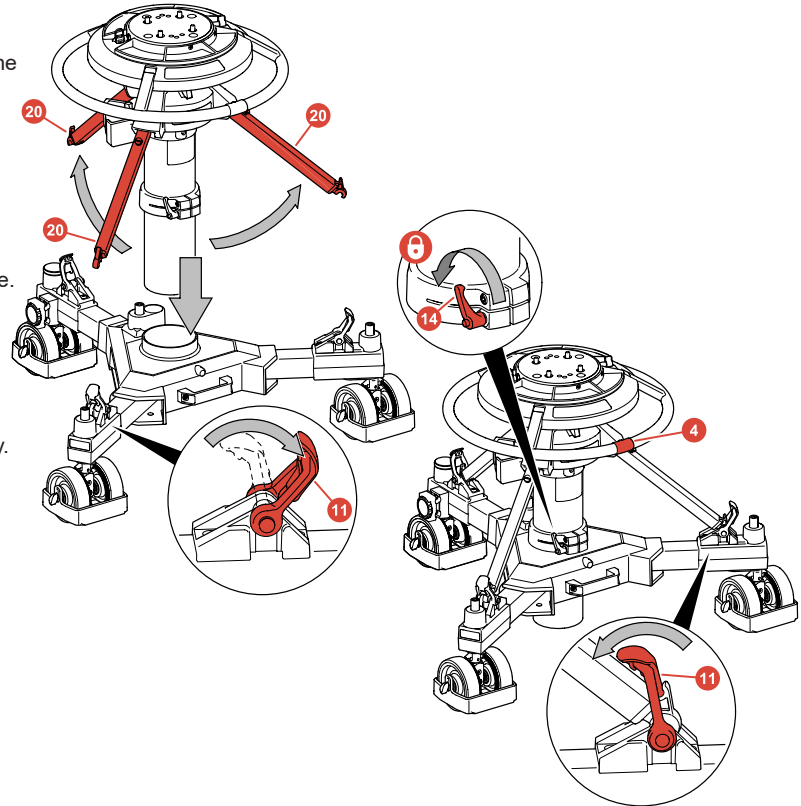

Pressurizing the pedestal

The pedestal may be pressurized using the built-in pump, by using the Portable Pump or from an external pressure source.

Ascertain the payload to be fitted to the pedestal (payload = fluid head, camera, lens and all ancillary equipment). Referring to the graph below, mark the payload on the horizontal axis then strike a vertical line from the load figure to the balance line. At the intersecting point strike a horizontal line to the vertical axis and read off the required gas pressure.

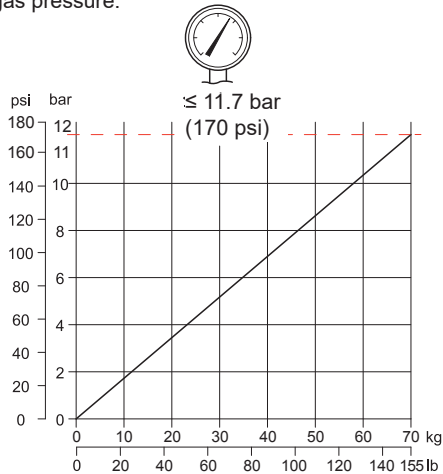

WARNING! Do not pressurize the pedestal beyond the maximum safe working pressure indicated by the leading edge of the red sector on the gauge. The pedestal is fitted with a pressure relief valve as a safeguard against over-pressurization. Do not attempt to adjust the pressure relief valve. Remove the payload before pumping.



WARNING! This pedestal must be pressurized only with clean, dry air or nitrogen. A pressure reducing valve must be fitted to the pressure line between the as cylinder and the outlet connection of the hose. The reducing valve must be screwed into the gas cylinder outlet. The maximum pressure on the outlet side of the reducing valve must not exceed 11.7 bar (170 psi). Do not pressurize the pedestal beyond the maximum safe working pressure indicated by the leading edge of the red sector on the gauge. The pedestal fitted with a pressure relief valve as a safeguard against over-pressurization. Do not attempt to adjust the pressure relief valve.



WARNING! A pressurized pedestal will rise rapidly when safety catch is released. Do not release safety catch when pedestal is pressurized and balancing load is not installed. Always restrain the pedestal by hand pressure on the steering ring when the safety catch is released.



WARNING! Bottom stage elevation is assisted by a gas strut. The bottom stage will rise rapidly if released with no payload fitted. Do not lean over the pedestal when releasing the safety catch and/or the bottom clamp.



WARNING! A pressurized pedestal will rise rapidly if the control valve is set to WORK.

Do not move the control valve directly from PUMP to WORK.

Method	Advantages	Disadvantages
<ul style="list-style-type: none"> Integrated Pump (For units that have this.) 	<ul style="list-style-type: none"> No accessory needed Less strokes than manual Pump 	<ul style="list-style-type: none"> Cannot pump with payload fitted.
<ul style="list-style-type: none"> Gas Bottle 	<ul style="list-style-type: none"> Fast Can add gas with payload fitted 	<ul style="list-style-type: none"> Not always available Recommended training needed for working with compressed gas
<ul style="list-style-type: none"> Manual Floor Pump 	<ul style="list-style-type: none"> Easy for topping up. Readily available Self pump not available for all peds. 	<ul style="list-style-type: none"> Physically demanding so not recommended for payloads over 60kg. Some pumps cannot achieve max pressure on some models

Installation

To pressurize the pedestal using the built-in pump, proceed as follows:

To pressurize the pedestal manually, proceed as follows:



WARNING! Bottom stage elevation is assisted by a gas strut. The bottom stage will rise rapidly if released with no payload fitted. Do not lean over the pedestal when releasing the safety catch and/or the bottom clamp

1. Set the control valve (1) to the PUMP position.
2. Ensure that the bottom stage is fully lowered and the red bottom clamp (21) is applied. Remove the payload, if fitted.
3. Push down on the steering ring (24) against any residual pressure and release the safety catch (8).
4. Move the slide down into the unlock position.
5. Turn the steering ring to reveal the pressure gauge in weight tray aperture.
6. Using the steering ring, raise the top stage until fully extended. Commence pumping by lowering and raising the top stage over the upper half of its travel. When the pressure gauge (3) begins to register, pump the top stage over its full stroke. Stop pumping when maximum working pressure is reached (indicated by the lower edge of the red sector on the gauge) during the pumping stroke.

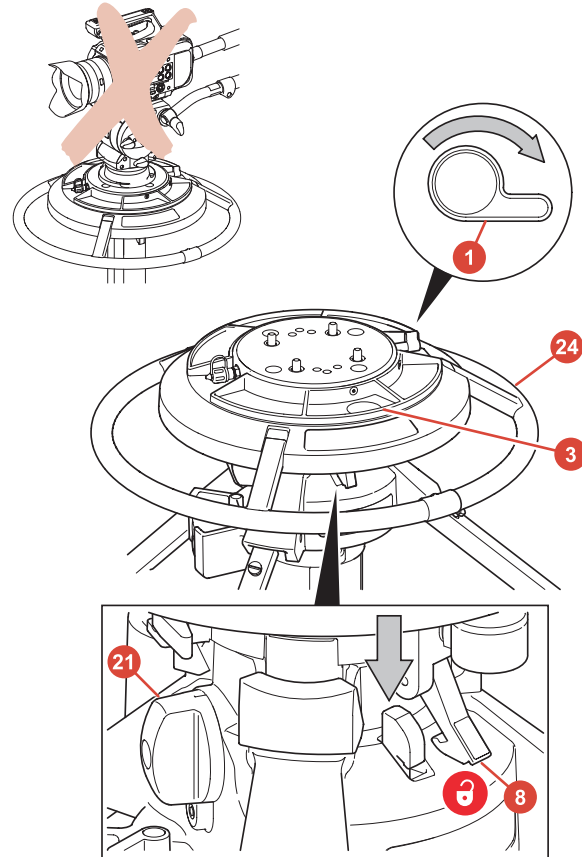



WARNING! A pressurized pedestal will rise rapidly if the control valve is set to WORK. Do not move the control valve directly from PUMP to WORK.

1. Push the control valve (1) in and turn 90° counter clockwise to the midway position between PUMP and WORK and release, pause for 5 seconds and allow the top stage to rise fully.

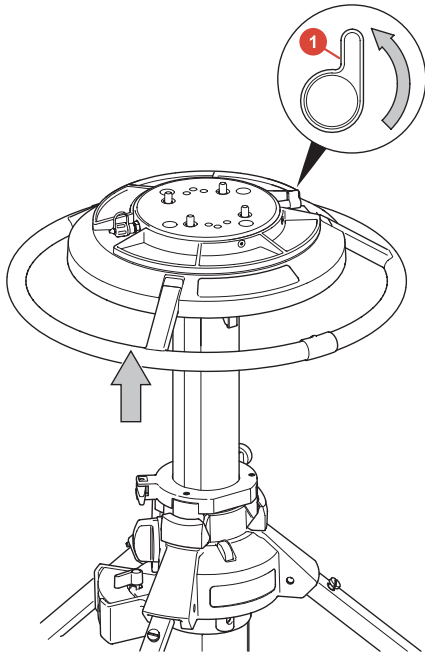

2. Push the control valve (1) in and turn 90° counter clockwise to the WORK position. Install the camera mount and payload and balance the load as described **Fitting and balancing the load** on page 16.

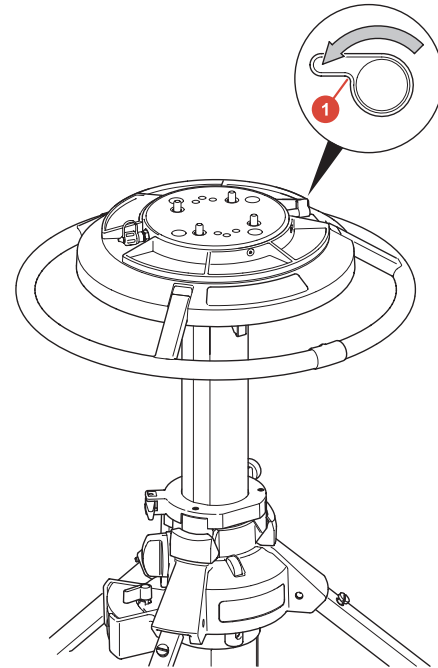

Installation

Pressurizing the pedestal using the portable pump



WARNING! Do not pressurize the pedestal beyond the maximum safe working pressure indicated by the leading edge of the red sector on the gauge. The pedestal is fitted with a pressure relief valve as a safeguard against over-pressurization. Do not attempt to adjust the pressure relief valve.



WARNING! A pressurized pedestal will rise rapidly when safety catch is released. Do not release safety catch when pedestal is pressurized and balancing load is not installed. Always restrain the pedestal by hand pressure on the steering ring when the safety catch is released.

To pressurize the pedestal using the portable* pump, proceed as follows:

Attach the intended payload, see **Fitting and balancing the load** on page 16

1. Set the control valve (1) to the WORK position.
2. Fully depress the moving column and engage the safety catch (8).
3. Turn the Steering ring (24) so the pressure gauge can be seen through the weight tray.
4. Connect the pump adaptor (5) to the pedestal charging valve (23) by turning clockwise until finger tight.
5. Connect the pump hose to the pump adaptor (5) and flip it upwards to secure.
6. Position the pump between the legs, standing with both feet on the pump feet.
7. Grip the pump handle with both hands and using full steady

strokes, pressurize the pedestal to the required pressure. Do not exceed the maximum working pressure, indicated by the leading edge of the red sector on the gauge.

8. Disconnect the hose from the pedestal charging valve, but do not refit the Schrader valve cap at this stage. Push the pump plunger fully down, and store.

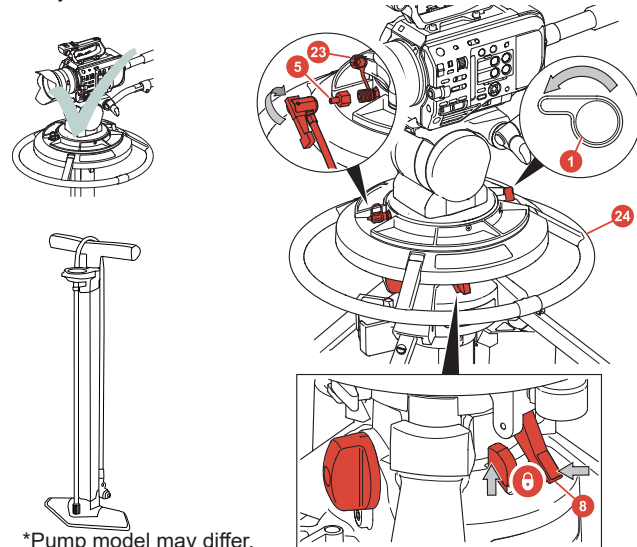

Note! In the event that the pedestal air pressure has dropped to 0 psi, proceed as follows: Follow steps 3 to 4. The pump features a shock function (Lever in Position A), this allows the pump to store pressure with every stroke up to approximately 75psi. When this pressure is achieved turn the lever to position B. This will force the O-ring in the pedestal to seal. Resume from step 5.

Pressurizing from an external pressure source



WARNING! This pedestal must be pressurized only with clean, dry air or nitrogen. A pressure reducing valve must be fitted to the pressure line between the gas cylinder and the outlet connection of the hose. The reducing valve must be screwed into the gas cylinder outlet. The maximum pressure on the outlet side of the reducing valve must not exceed 11.7 bar (170 psi).

Do not pressurize the pedestal beyond the maximum safe working pressure indicated by the leading edge of the red sector on the gauge. The pedestal is fitted with a pressure relief valve as a safeguard against over-pressurization.

Do not attempt to adjust the pressure relief valve.



WARNING! A pressurized pedestal will rise rapidly when safety catch is released. **Do not** release safety catch when pedestal is pressurized and balancing load is not installed. Always restrain the pedestal by hand pressure on the steering ring when the safety catch is released.

To pressurize the pedestal from an external pressure source, proceed as follows:

1. Set the control valve (2) to the WORK position.
2. Push down on the steering ring (24) against any residual pressure and engage the safety catch (7).
3. Attach the intended payload, see **Fitting and balancing the load** on page 1616
4. Turn the Steering ring so the pressure gauge (3) can be seen through the weight tray
5. Remove the Schrader valve cap (23) and connect the charging line from the pressure source.
6. Turn on the pressure supply and slowly increase the pedestal pressure. Shut off the supply when maximum working pressure is reached, indicated by the lower edge of the red sector on the gauge (3).
7. Disconnect the hose from the pedestal charging valve, but do not refit the Schrader valve cap at this stage.

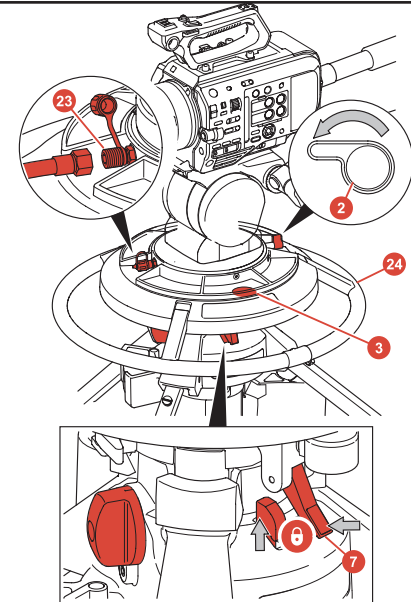

Installation

Fitting and balancing the load

The pedestal has the standard four-bolt mounting plate which permits the use of various Sachtler fluid heads or optional accessories with four-bolt fixing (See Optional Accessories page 8). The mounting bolts are captive in the pedestal and the bolt heads are accessible from the underside of the mounting plate.

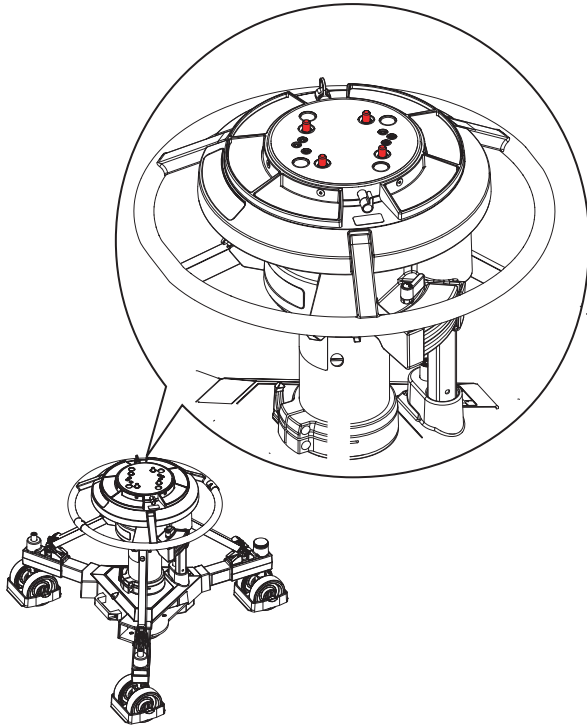

For access to the bolts:

1. Apply the brakes, ensure the pedestal has **only 50psi** of pressure.
2. Apply downward pressure to the top plate, unlatch the safety catch.
3. Using hand guidance, allow the column to rise to its maximum height.



WARNING! A pressurized pedestal will rise rapidly when safety catch is released. **Do not** release safety catch when pedestal is pressurized and balancing load is not installed. Always restrain the pedestal by hand pressure on the steering ring when the safety catch is released.

1

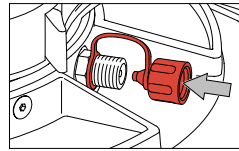

=

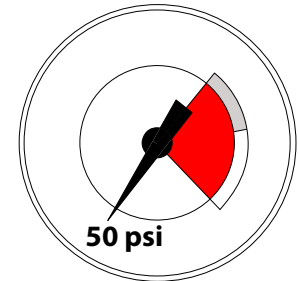

2



3

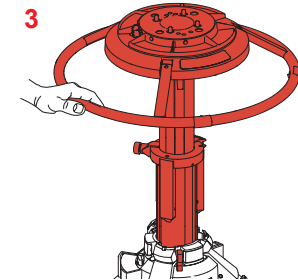



CAUTION! It is recommend a second person hold the payload steady while another person tightens the screw bolts.

Recommend two person fit.

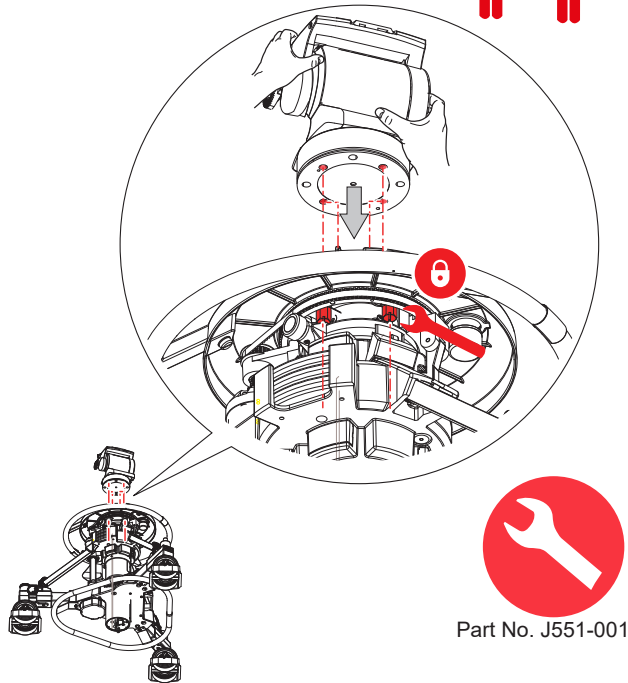
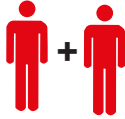

Part No. J551-001

When the camera mount has been fitted, the bolts should be tightened securely using a spanner of the correct size.

A spanner, Part No. J551-001, is available for this purpose.

Lower and re-latch the column before adding the remainder of the payload such as pan bars, prompters, lenses etc. Attaching these items at a later stage may upset the pedestal balance. and fully pressurising.

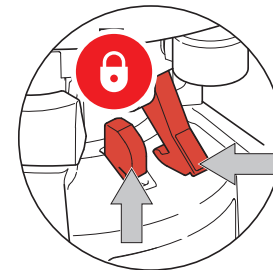
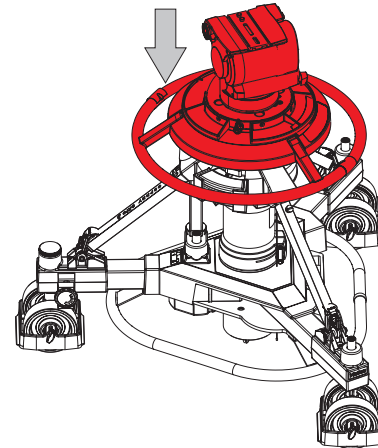

Installation

Fitting and balancing the load with the Optional Heavy Duty Quickfix Adaptor

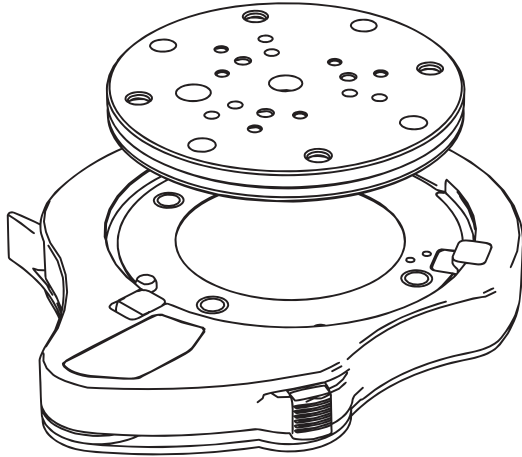

1. Install Quickfix adaptor (Installation is explained in the previous section_Page 16.)
2. Attach Multi Disc to Sachtler Studio head (except Video 90)
3. Push up the red safety latch and unlock the adaptor by pulling the lever fully outwards and to the left.
4. Position the head in the adaptor, ensuring that it seats correctly in the recess and the safety button is depressed.

5. Lock the head in the adaptor by pushing the lever fully inwards to the right until the red safety latch operates.

To remove a head

1. Push up the red safety latch and unlock the adaptor by pulling the lever fully outwards and to the left.



WARNING! This unit contains a spring under tension. Removal of the backplate may cause personal injury.

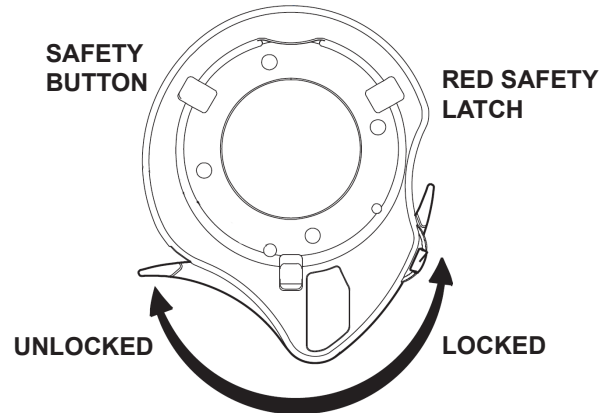

1. Fit the adaptor to the ped first, then the head followed by the camera, red indicates moving parts not assembly sequence. Once the head is fitted follow head and accessories manuals to securely fit all of he payload (which may include camera, lens, teleprompter, viewfinder and accessories).
2. With the full payload fitted, hold the steering ring down and release the safety catch carefully allowing the top stage of the pedestal to extend. Ensure pan bars, prompters, lenses etc are fitted. Attaching these items at a later stage may upset the pedestal balance.
3. Using the Schrader valve cap, carefully reduce the pressure in steps of 0.15- 0.20bar (2-3psi) until the payload is correctly balanced.

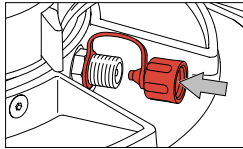

A correctly pressurized pedestal will balance its payload, it may be moved to any position over the full on-shot stroke with minimum effort and will maintain its position when the steering ring is released.



WARNING! The Schrader valve cap (23) forms a primary pressure seal. Always replace the cap and screw it down finger-tight.

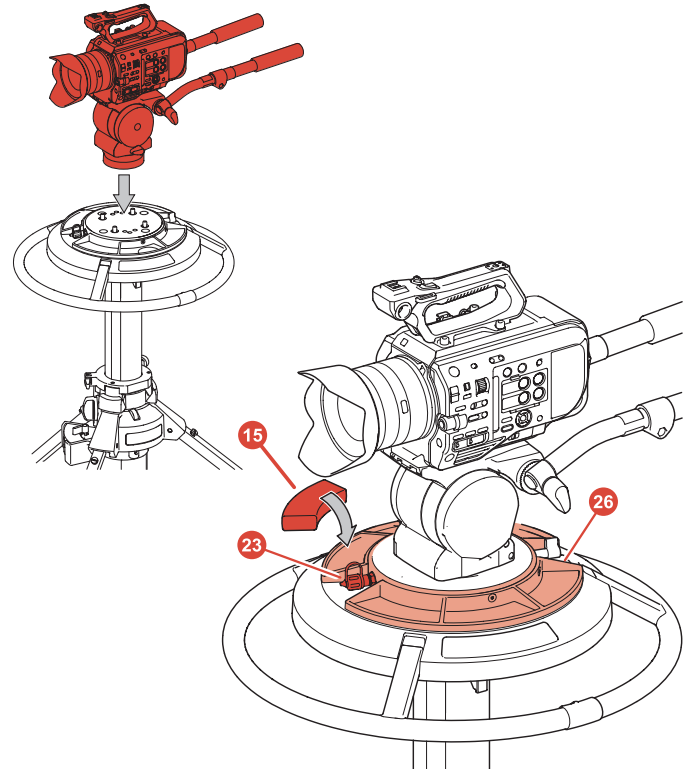
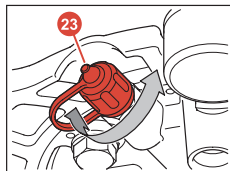

3. Fine balance and temperature correction may be achieved by adding or removing trim weights (15).

Height adjustment



Lower stage pressure-assistance is provided by a gas strut located within the column.
The strut is available in three pressure settings (See below) and the correct one should be installed according to the pedestal load. (See **Replacing gas struts** on page 30).

Lower stage

The elevation tube forms the lower stage of the pedestal height adjustment and has a range of 395 mm (15.5 in.), and is pressure-assisted to aid elevation whilst the pedestal is loaded. To adjust the height setting:

1. Lower the top stage and engage the top clamp (6).
2. Support the weight of the load by holding the steering ring (5) and then slacken the bottom clamp (21) by turning the red knob counter-clockwise until the lower stage is free to move.
3. Use the steering ring to set the column at the required height and re-tighten the bottom clamp.

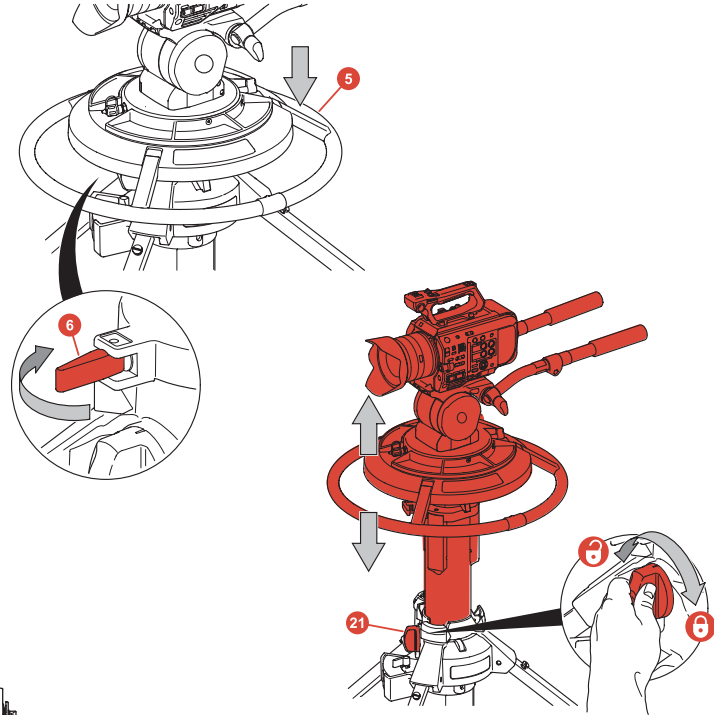
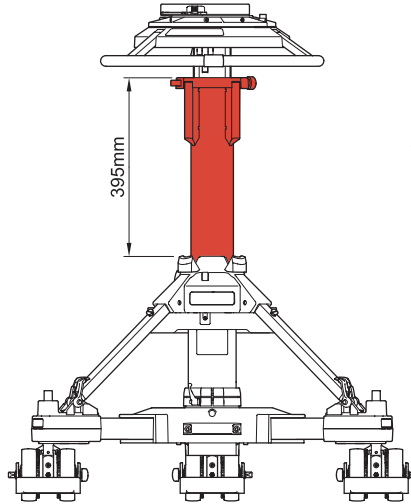

Strut	Payload / Force	Part No.
Factory Fitted	30-55 kgs / 450N	3328--305
Supplied loose	55-70 kgs / 600N	3328-385
Available to purchase	0-30kgs / 270N	3328-307

Top stage

The top stage of the column has an on-shot stroke of 410 mm (16.1 in) and the load can be moved over this distance, in perfect balance, by raising and lowering the steering ring. The movement is adjustable for drag and this is set according to operator preference by means of the drag control (22) located at the top of the lower stage.

1. Turn the control clockwise to increase the drag setting, and counter-clockwise to decrease it.
2. A clamp for the top stage (6) is fitted to the pedestal. This can be used to hold the top stage in position if fixed height operation is required. Move the clamp lever fully to the left to apply the clamp. Move it fully to the right to release the clamp.

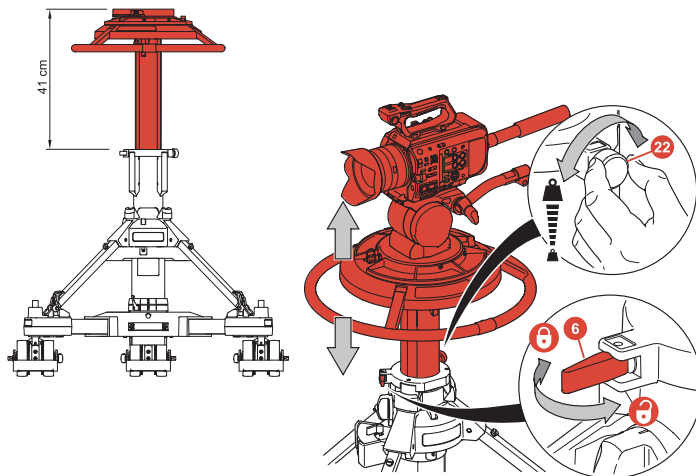

Brakes

Each of the skid wheels is fitted with a foot operated brake. The brakes are operated by pressing on the foot-buttons (4) located above the wheels. Press once to apply the brake and again to release it.

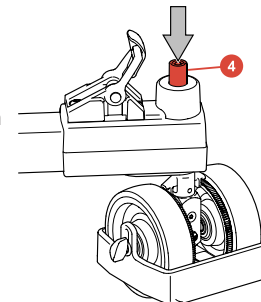

WARNING! Always apply the brakes when the pedestal is left unattended.

Cable guards

The cable guards (17) are height-adjustable and should be set as required.

Adjustment is carried out by slackening the knobs (17.1), setting the cable guards at the required height and re-tightening the knobs.

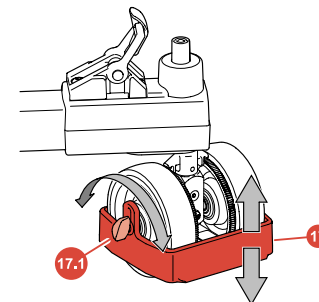

Pedestal movement

Directional control of the pedestal is achieved by turning the steering ring mounted at the top of the column. The steering system is geared so that the skid wheels turn by the same amount as the steering ring. This ensures, for example, that with the pedestal set to crab, turning the steering ring by 90° will also cause the pedestal to change direction by 90°. The steering ring is fitted with two movable indicators (4) which can be used to mark the straight-ahead position of the ring and will provide a reference point when steering.

Movable indicators

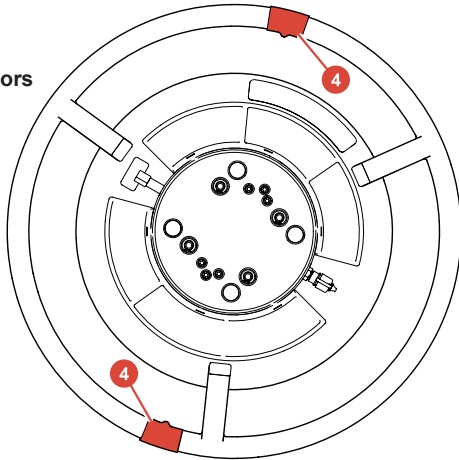

The skid has a crab/steer arrangement with a foot-operated changeover mechanism, which provides a steer setting i.e. one wheel steering, two fixed; or a crab setting, where all three wheels turn together.

Pushing the foot-button (16) operates a changeover mechanism which toggles the pedestal between crab and steer. The button can be pressed with the wheels in any position, but the changeover will not occur until the wheels are all facing forward, so the steering ring may have to be turned by up to 180° before the changeover mechanism engages. This arrangement ensures that the rear wheels will always lock in the straight-ahead position when changing from crab to steer.

A clutch in each wheel unit disconnects that wheel from the steering in the event of the wheel striking an obstacle. To reconnect the wheel, hold the steering ring stationary and turn the wheel unit until the clutch re-engages.



WARNING! To ensure maximum stability, particularly when moving over uneven ground, reduce pedestal height to a minimum.

Position 1 for one wheel steering with two fixed wheels.
Position 3 for Crab steer, all three wheels turn together.

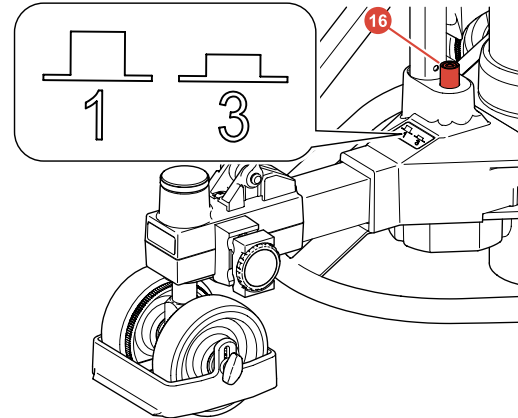

Operation

Changing the skid tracking width

The movable skid legs can be set to either of two positions. **1:** Wide for normal use, maximum stability. **2:** Narrow for a reduced width for tracking through narrow doorways etc.

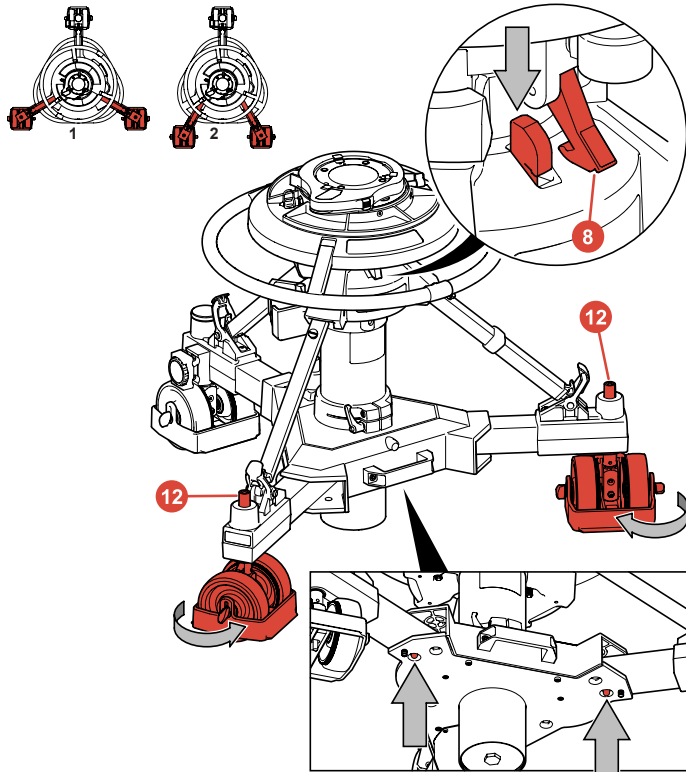

WARNING! To ensure maximum stability when the skid is set to narrow track, particularly when moving over uneven ground, reduce pedestal height to a minimum

Set the column to its lowest setting and engage the safety catch (8).

Ensure that the brakes (12) are released and then turn the skid wheels so they are pointing at right angles to the skid legs.

Reach under the pedestal, depress one of the spring-loaded locking plungers and move the leg to the required position, ensuring that the plunger has engaged correctly at the new location, repeat for the second leg.

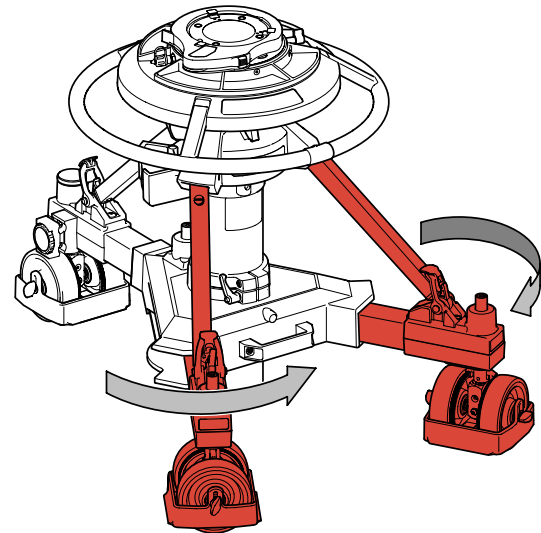

Optional wheels

A set of 160 mm (6.3 in.) wheels (Part No. 3329-30) is available to convert the skid from studio to OB use.

A set of 125 mm (5 in.) wheels with cable guards (Part No. 3329- 43) is available to convert an OB skid to a studio skid.

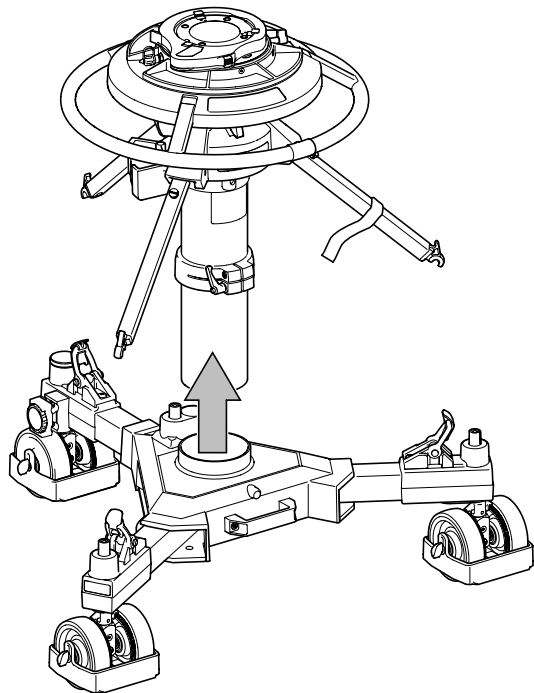

To replace the wheels:

Remove the column from the skid (see **Transportation and storage** on page 26(and turn the skid upside down.

Unscrew and remove the countersunk screw (1) securing the wheel assembly (2) to the shaft (3).

Remove the wheel assembly, complete with cable guard.

Repeat for remaining two wheel assemblies. Store the wheels for future use.

Fit the replacement wheel assemblies (4) to the shafts (3) and secure each wheel assembly to the shaft with the countersunk screws (1).

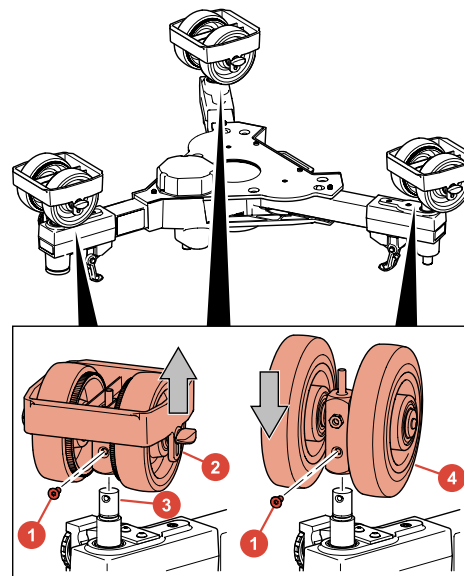

Operation



WARNING! Local, national or international regulations may apply to the transport and storage of pressurized pedestals.



NOTE: It is not necessary to reduce the pedestal pressure prior to transportation or storage. To avoid the possibility of dust or abrasive particles collecting on moving components, set the column to minimum height.

Transportation and storage

The column and skid may be separated to facilitate transport or storage.

To separate the column and skid:

1. Apply the brakes (12).
2. Set the control valve (1) to the WORK position.

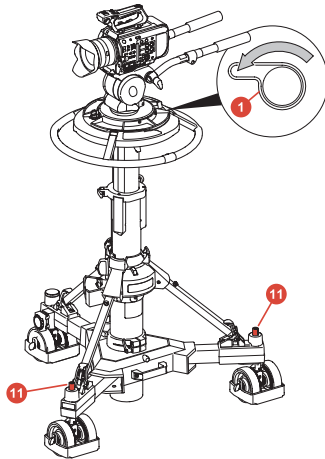

3. Lower the top stage (5), then set the control valve to PUMP

4. Remove the load and secure any trim weights (15) in the trim weight storage (9).

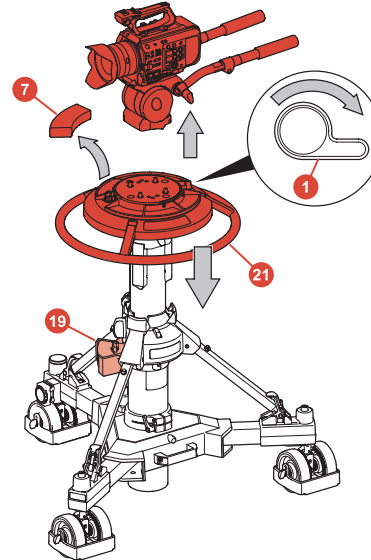

5. Set the safety catch slide (8) to LOCK position (I) and fully depress both columns until the safety catch engages and tighten the bottom clamp (3).
6. Release the skid clamp (14).
7. Release the three rubber foot straps (11) from the struts.
8. Raise each strut. They will remain raised when released then lift the complete column vertically off the skid.
9. Turn the skid over, depress the locking plungers and fold the skid legs, ensuring that the plungers lock in the closed position.

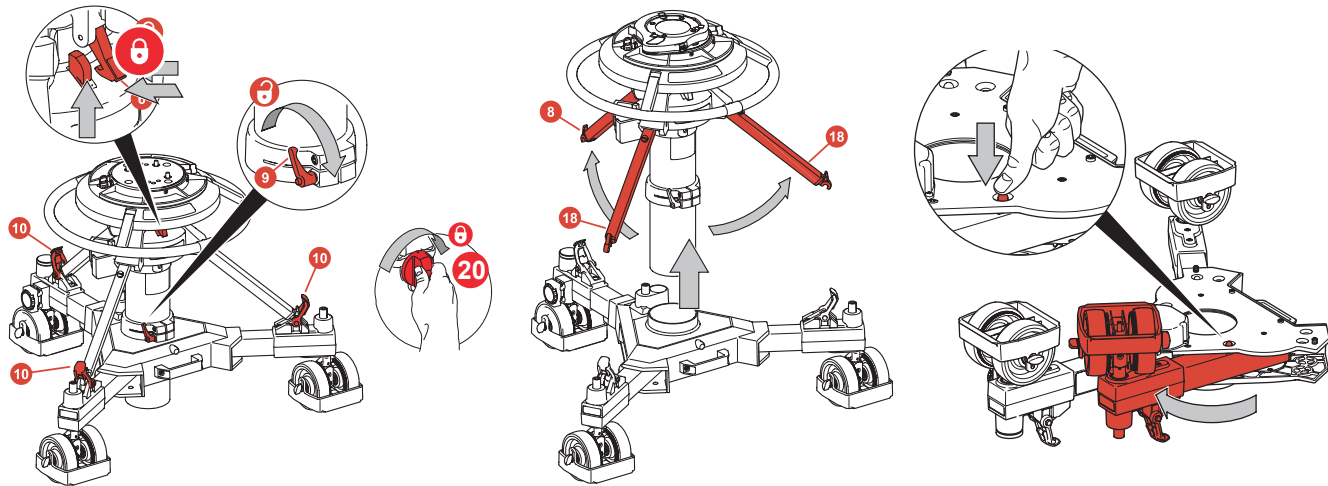

WARNING! The column will be unstable if stood on its base or on the folded struts.

Servicing

General

The Vario Ped is robustly made to high engineering standards and little attention is required to maintain serviceability except for regular cleaning. Attention to the following points will ensure a long and useful service life with minimum need for repair.

Cleaning

During normal studio use, the only cleaning required should be a regular wipe over with a lint free cloth. Dirt accumulated during storage or periods of disuse may be removed with a semi stiff brush. Particular attention should be paid to the flats on the top stage of the column.



CAUTION! Do NOT use oil or grease on any exposed part of the column. This is unnecessary and traps dirt which acts as an abrasive.

Use out-of-doors will require special attention, especially in adverse conditions. Salt spray must be washed off with fresh water at the earliest opportunity. Do not allow water to enter the column.

Sand and dirt acts as an abrasive and should be removed with a semi-stiff brush or vacuum cleaner.



NOTE: Use only detergent-based cleaners. Do NOT use solvent- or oil-based cleaners, abrasives or wire brushes to remove accumulations of dirt, as these damage the protective surfaces.

Routine Maintenance

The Vario Ped requires minimal routine maintenance, apart from checking the connections and overall operation periodically.

Check the following points during normal use:

- Check for ageing and cracking of the rubber securing straps and renew if necessary.
- Check the effectiveness of the clamps.
- Check for radial or side play in the top stage.

Adjustments

Adjustments which may become necessary after considerable use are as follows:

- Taking up wear in the bottom clamp.
- Taking up wear in the skid clamp.
- Elimination of radial and side play on the top stage.

Bottom clamp adjustment

When the bottom clamp is correctly adjusted, the V notch on the bottom clamp knob (4) should be just before the 12 o'clock (vertically upwards) position when the clamp is fully applied. If it is necessary to adjust the bottom clamp, proceed as follows:

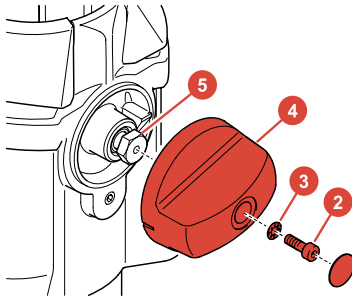

Remove the hole plug (1). Remove the screw (2) and washer (3) securing knob (4) to the spindle (5).

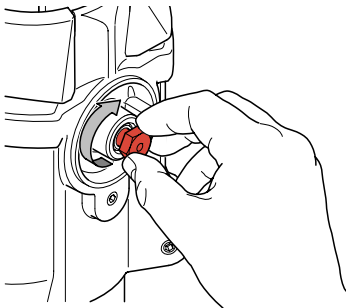

Remove the knob and turn the spindle (5) clockwise until finger-tight.

Replace the knob (4) on the spindle (5) so that the 'V' notch on the clamp knob is within the limits shown.

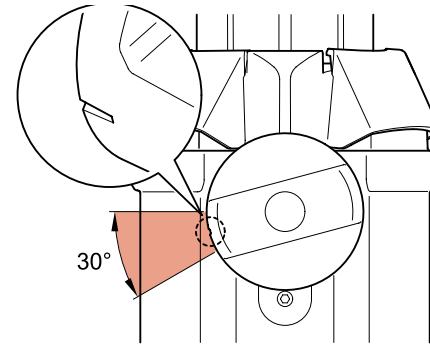

Degrease screw (2), coat with Loctite 222E and secure knob with washer (3) and screw (2). Replace hole plug (1).

Maintenance

Skid clamp adjustment

The top clamp is applied by pulling the flip lever out. The skid clamp is applied and released by turning the handle clockwise or counter-clockwise. The skid clamp is fitted with a push-on/pull-off type ratchet adjustment. The top clamp has a flip lever.

To adjust the skid clamp pull the clamp handle away from the spindle, rotate it counter clockwise and release.

Repeat the above procedure, as necessary, until the clamp locks when applied but allows free movement when released.

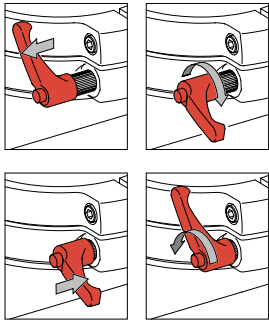

Skid Clamp

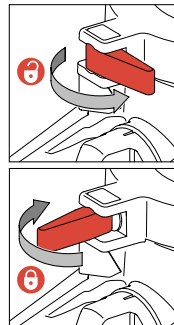

Top Clamp

Elimination of radial and side play on the elevation tube or top stage

If excessive radial or side play is apparent on the elevation tube or top stage. Then this adjustment should be carried out by a competent and suitably trained person.

Replacing gas struts

Bottom stage elevation assistance is provided by a gas strut located in the telescopic column. To allow for various column loads, three versions of the strut are available, each designed to operate over a particular load range.

To replace the bottom stage gas strut:

1. Apply the wheel brakes (12), set the top stage (5) to its **maximum height** and engage the top clamp.

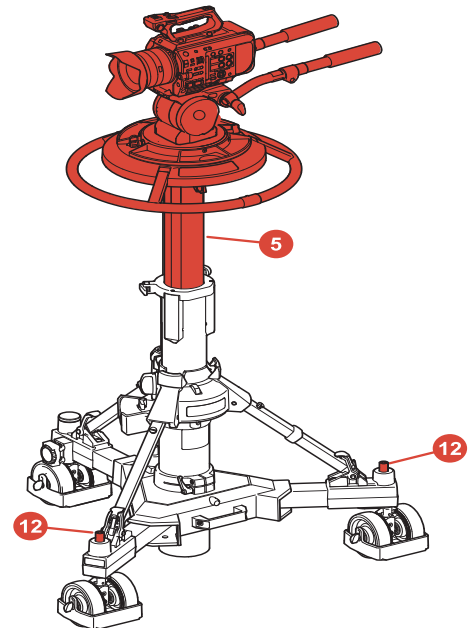

2. Remove the load, release the bottom clamp (21) and set the bottom stage (7) to its maximum height. **Both stages must be fully extended and the payload removed.**
3. Tip the pedestal over and carefully lay it on its side.

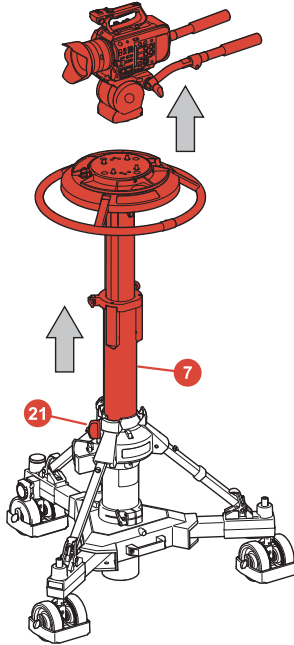

4. Unscrew and remove the centre end plug (23) from the base of the telescopic column.
5. Withdraw the gas strut (24) from the column.
6. Fit the new gas strut, cylinder end first, carefully guiding it up through the column until it is fully engaged.
7. The strut is correctly fitted when the thread on the end plug (23) can be started in the column without compressing the strut.
8. Tighten the end plug.
9. Carefully stand the pedestal upright.

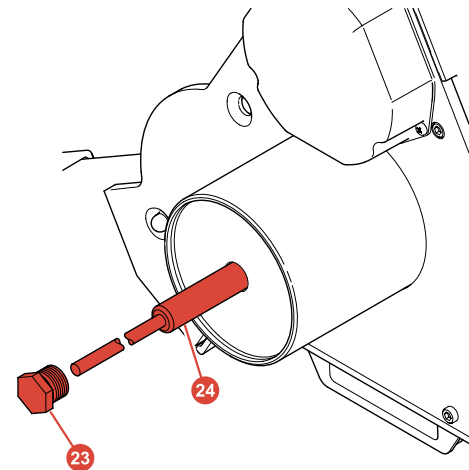

Strut	Payload / Force	Part No.
Factory Fitted	30-55 kgs / 450N	3328--305
Supplied loose with Pedestal	55-70 kgs / 600N	3328-385
Available to purchase	0-30kgs / 270N	3328-307



WARNING! Make sure that the pedestal is at its maximum height before tipping it over and removing the centre plug. If not **do not** attempt to remove the nut (23) as the strut will be ejected under pressure.

Technical Specification

Physical Data (Vario Ped 1-70 S2302-0001)



Minimum height
670 mm (26.4 in.)



Tracking Width
970 mm (38.2 in.)



Maximum height
1480 mm (58.3 in.)



Doorway Tracking Width
730 mm (28.7 in.)



Maximum payload
70 kg (154 lb)



Stages
2



Weight
39.5 kg / 87.1 lb



Max working pressure
≤ 11.7 bar (170psi)



Steering Ring Diameter
533 mm (21 in.)



Relief valve pressure
12 bar (187 psi)



On-shot stroke
410 mm (16.1 in.)



Ground clearance
20 mm (0.8 in.)



Transit Width
800 mm (31.5 in.)

Environmental Data



Operating temperature range
+5°C to +40°C (41°F to +104°F)



Storage temperature range
-20°C to +60°C (-4°F to +140°F)

Technical specifications are subject to change without notice.

EU Declaration of Conformity

Videndum Production Solutions Ltd. declares under our sole responsibility, supported by Videndum Production Solutions GmbH - our authorized representative, that the product detailed in this manual conforms with all relevant provisions of the following EU directives:

Machinery Directive 2006/42/EC

A copy of the declaration is available on request.

EU contact: Videndum Production Solutions GmbH, Parkring 29, 85748 Garching, Germany

UK Declaration of Conformity

Videndum Production Solutions Ltd. declares under our sole responsibility that the product detailed in this manual conforms with all relevant provisions of the following UK Regulations:

The Supply of Machinery (Safety) Regulations 2008

A copy of the declaration is available on request.

UK contact: Videndum Production Solutions Ltd, William Vinten Building, Easlea Road, Moreton Hall Estate, Bury St. Edmunds, IP32 7BY

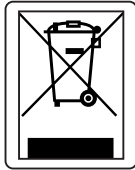

Environmental considerations

European Union Waste of Electrical and Electronic Equipment (WEEE) Directive (2002/96/EC)

This symbol marked on the product or its packaging indicates that this product must not be disposed of with general household waste. In some countries or European Community regions separate collection systems have been set up to handle the recycling of electrical and electronic waste products. By ensuring this product is disposed of correctly, you will help prevent potentially negative consequences for the environment and human health. The recycling of materials helps conserve natural resources.

Visit our website for information on how to safely dispose of this product and its packaging.

In countries outside the EU:

Dispose of this product at a collection point for the recycling of electrical and electronic equipment according to your local government regulations.

Pollution statement

This equipment is designed for operation in Pollution Degree 2 environments.

Publication No. S2302-4980/0

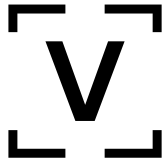

Sachtler
A Videndum plc Brand

www.videndum.com