

PROTECH LED

be creative

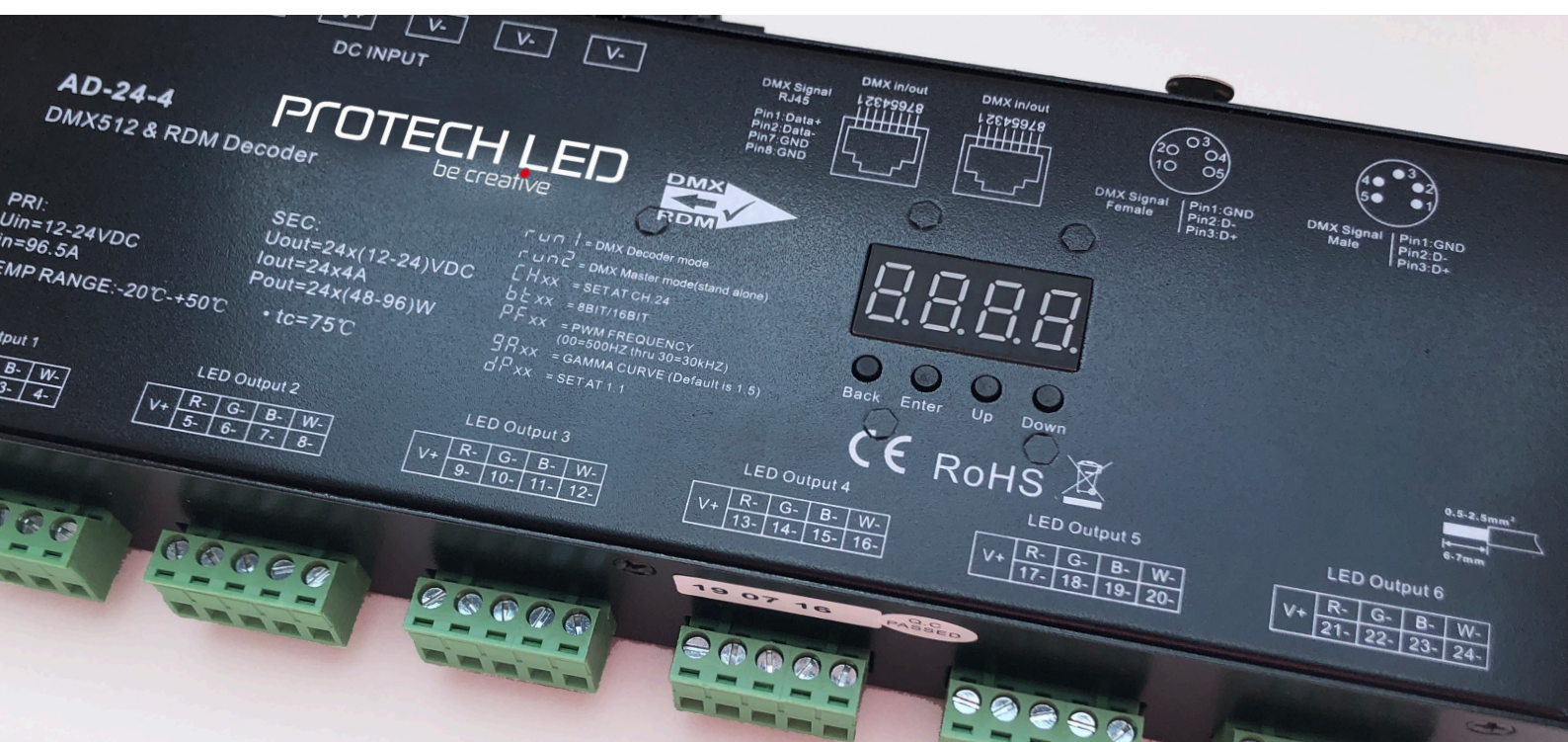

DMX DRIVER AD-24-4



AD-24-4

FUNCTION INTRODUCTION

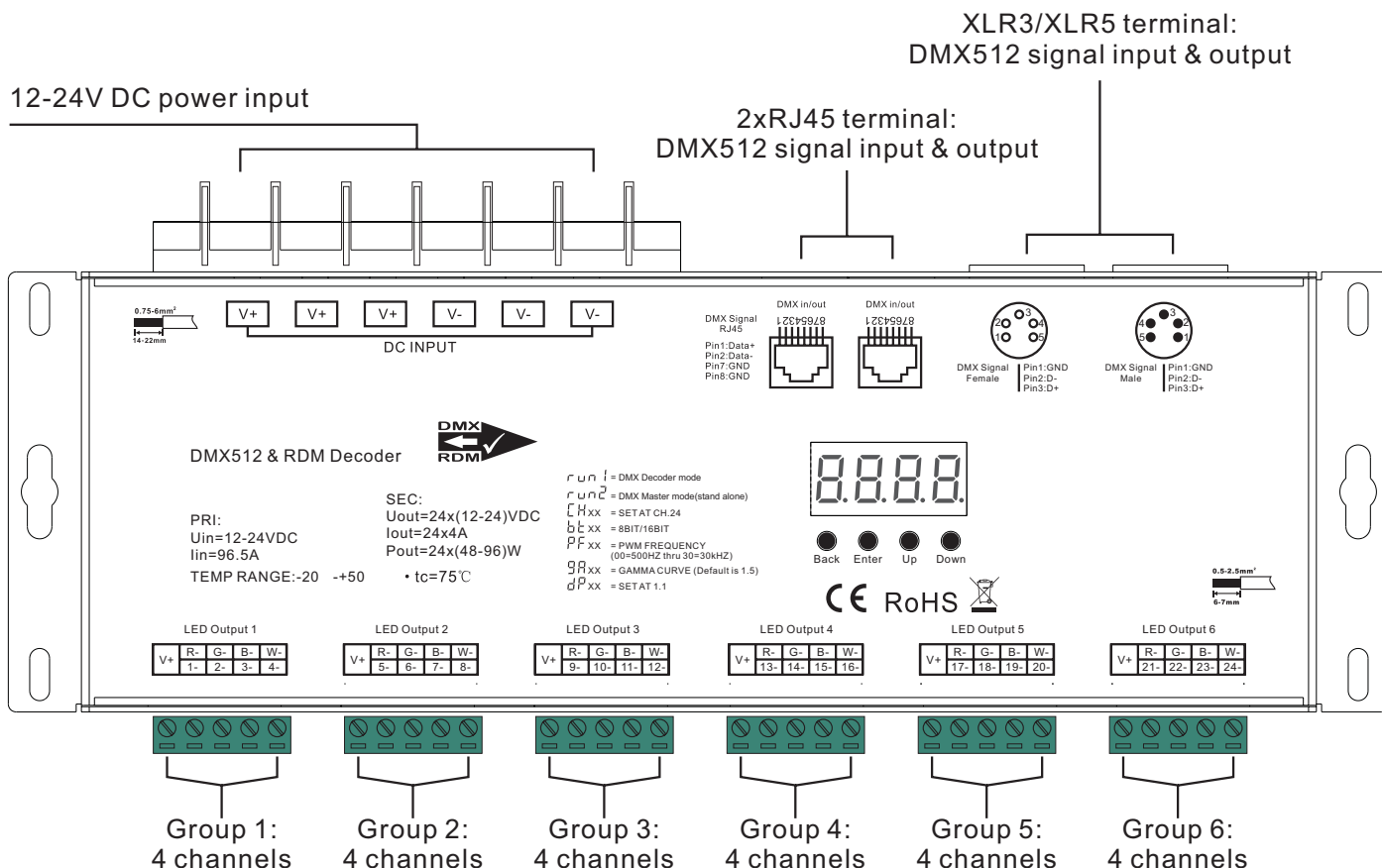

- Master & decoder mode, RDM function
- DMX512 RDM decoder, RDM function can realize intercommunication between DMX master and decoder. for example, you can set DMX decoder's address by DMX master console.
- Metal housing, digital display to show data directly, easily to set and show DMX address.
- With multiple kinds of DMX in/out ports: RJ 45, XLR , normal screws.
- Total 24 PWM output channels, common anode. DMX channel quantity from 1CH~24CH settable
- PWM output resolution ratio 8bit , 16bit settable.
- Output PWM frequency from 500HZ ~ 30K HZ settable.
- Output dimming curve gamma value from 0.1 ~ 9.9 settable.
- Decoding modes optional, enable to adjust brightness of each channel, master brightness of all channels and strobe e-ffects.
- Decoding mode settable.
- Galvanic isolation

PRODUCT DATA

Input Voltage	Output channels	Output Current	Output Power	Type	Dimension (mm)
12-24V	24	4 Amp/ch	48-96W/CH	Constant voltage	265x83x42mm

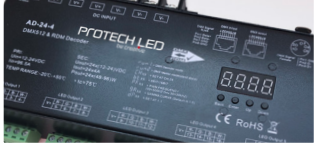

AD-24-4

WIRING DIAGRAM

UNDER MASTER MODE (stand alone)

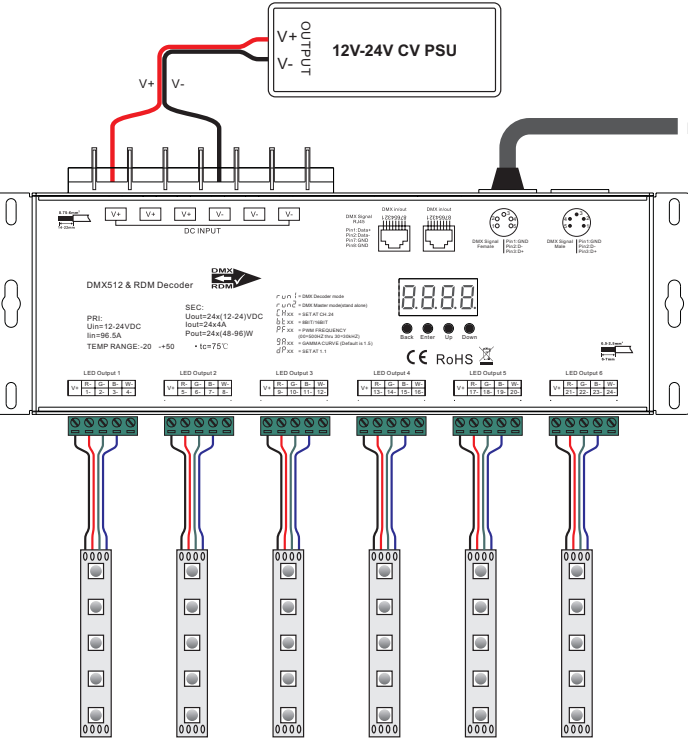

UNDER DECODER MODE

